

Quick Start Guide



FIND YOUR GLORY

AGM G2/G2 PRO/G2 Guardian

Thank you for choosing AGM!

Features of the product and its accessories described herein rely on the software, phone internal memory and local networks, and may not be activated or may be limited by local network operators or service providers. Therefore, the descriptions herein may not exactly match the purchased product or its accessories.

The manufacturer reserves the rights to change or modify any information or specifications contained in this manual without prior notice or obligation.

The manufacturer is not responsible for the legitimacy or quality of any products that you may upload or download through this device including but not limited to text, images, music, movies, and non-integral software.

Any consequences arising from the usage of the preceding products on this device is the responsibility of the user.

AGM G2/G2 PRO/G2 Guardian

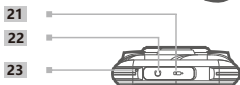
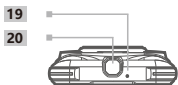
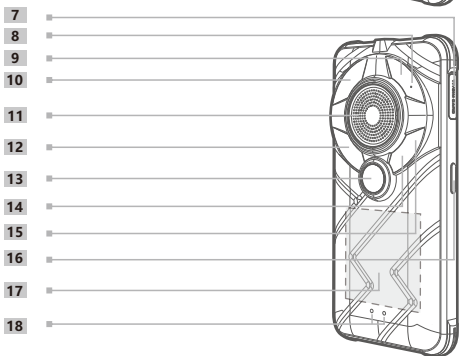
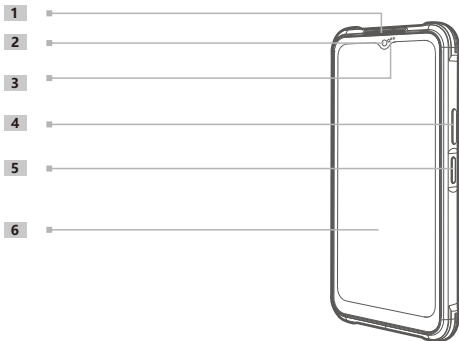

- 1 Receiver**
>Waterproof receiver. Do not touch with hard pin
- 2 Front Camera** 32MP
>Takes front facing photos
- 3 Sensors**
>Optical proximity sensor and Ambient light sensor
- 4 Volume Key**
>Press to increase/decrease the phone volume
>Press to mute the phone during an incoming call
- 5 Fingerprint/Power Key**
>Fingerprint sensor
>Long press power key to power phone on/off
>Short press power key to lock/unlock the screen.
- 6 Display**
>6.58inches Display
- 7 SIM/SD Tray and Waterproof Rubber cover**
>Supports Nano SIM and Micro SD card
- 8 Air Pressure Balance Hole**
- 9 Macro Camera** 2MP
- 10 Main Camera** 108MP
>Takes photos and videos
- 11 LOUDSPEAKER**
>Waterproof speaker. May be adjusted to a comfortable volume.
>The speaker volume may become lower after immersion in water but will recover once dry.
- 12 LED**
>LED flash light.
- | 13 AGM G2 | AGM G2 PRO | AGM G2 Guardian |
|------------------|---|--|
| Breathing lamp | Thermal Imaging Camera
>Fixed focal length | Thermal Imaging Camera
>Variable focal length |
- 14 Infrared Night Vision Camera** 20MP
>Take photos in dark areas
- 15 Infrared LEDs**
>Night Vision Camera Fill Light
- 16 PTT KEY/USER DEFINED KEY**
>Push to talk key. User can also define it as Audio Play, Camera or LED Torch.
>Press and hold to activate the defined functions when screen is unlocked.
- 17 Area of NFC**
- 18 Charging Connection Spots**
>Desktop dock connection spots.
- 19 Sub MIC**
>Noise reducing waterproof microphone. Do not touch with hard pin
- 20 Torch**
>High brightness top LED torch.
- 21 USB Type-C port and Waterproof Rubber Cover**
- 22 3.5mm Headphone Jack and Waterproof Rubber Cover**
- 23 Main Microphone**
>For talking and voice recording. Do not touch with hard pin

Useful tips:

1. In case the system stops working, press and hold down the power button until your device vibrates then release.
2. Do not cover Receiver, Main MIC and Sub MIC.
3. Adjust the volume to a comfortable level to prevent hearing damage.

Waterproof warning:

1. **AGM G2** is IP68/IP69K/MIL-STD-810H certified.
2. USB waterproof rubber cover and SIM/SD tray waterproof rubber cover must be completely closed to prevent water damage.
3. If the phone does come in to contact with water, it may affect the audio for a short period. In this case please dry the phone using a clean cloth and then allow it to stand and dry naturally for 30 minutes. This should restore the audio to the correct position.
4. Please do not use any other method, hairdryers for example, other than that listed above to dry your phone as this will affect the phone performance.
5. If you phone has received a strong shock or has been bent or twisted ensure that it does not come in to contact with water.

Network frequency band (*Variant dependent)

GSM: 850,900,1800,1900

CDMA: BC0, BC1, Bc10

WCDMA: B1,B2,B4,B5,B6,B8,B19

LTE-FDD:

B1,B2,B3,B4,B5,B7,B8,B12,B13,B17,B18,B19,B20,B25,B26,B28AB,B66,B71

LTE-TDD: B34,B38,B39,B40,B41

5G: n1,n2,n3,n5,n7,n8,n28,n41,n66,n71,n77,n78,n79

PREPARING TO INSTALL THE SIM/MICRO SD CARD

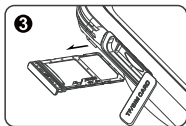
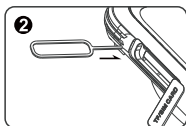
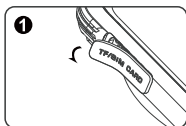

Installing the SIM and Micro SD card:

1. Take off the SIM/SD tray waterproof rubber cover and use your finger or the metal ejector pin provided to open the SIM tray.
2. Pull out the SIM tray.
3. Place Nano-SIM in inside position.
4. Place Nano-SIM or Micro SD card in outside position.
5. Make sure that the Nano-SIM and Micro SD card metal contact parts are facing down and that the cut corner aligned with tray in the correct position as per the diagram shown above.

SIM Tips:

1. * For some versions, **AGM G2** does not support 2 SIM cards data services working together. When inserting 2 SIM cards, you can only choose one of the 2 SIM cards to use 5G services.

The **AGM G2** supports dual SIM dual standby but single pass.

This means that you cannot use both SIM cards for calls or data services simultaneously.

2. Nano-SIM and Micro SD card socket can only be used for either Nano-SIM or Micro SD card. Place the Nano-SIM vertically or place Micro SD card horizontally.

3. Make sure the cards are correctly aligned and the tray is level before inserting it into the phone.

4. SIM card adapter. A cut SIM card or any other non-standard cards are not allowed. Those non-standard cards may not be recognized by the phone and can damage the tray.

Micro SD Tips:

1. Do not remove the Micro SD card while using the phone, as the card may be damaged. AGM will not be held responsible for any subsequent data loss or card damage resulting from this action.

2. Power off the phone before installing or removing the Micro SD card.

3. Please note that AGM does not provide Micro SD cards.

BATTERY AND CHARGING

Note: The **AGM G2** battery is not removable

Standby time:

1. The **AGM G2** standby time is dependent on different working environments.
 2. A Phone receiving a weak network signal and operating at low temperature will have a shortened standby time.
- Screen brightness, system settings, games, music, video, location services, camera, Bluetooth, Wi-Fi and applications consume the most battery power.

Charging the phone:

1. Plug the USB Type-C cable into the phone.
 2. Connect the USB power cable to the charging power adapter.
- * Some version **AGM G2** does not come along with a power adapter in the box. **AGM G2** supports CE/CB/FCC/CCC/EAC or equivalent certified chargers. Uncertified equipment may cause damage to the device or cause batteries to explode.
3. Open the USB Type-C port cover and connect the USB power cable to the port. Be careful not to use excessive force when plugging the cable. Any damage caused by attempting to insert the connector incorrectly is not covered by the warranty.
 4. Plug the charger into an AC mains socket.
 5. When charging is complete, remove the cable from the device, then unplug the power adapter from the mains socket. Close the USB port cover on the device.

Tips:

1. Fully charge the battery straight from the box, switching off the power when battery indicator shows full. Please do not leave the phone on charge when full as this may damage the battery and affect performance.
 2. Disconnect the charger from mains power supply when not in use.
 3. In the event of a fully discharged battery, please charge the phone for at least 15 minutes before powering it on.
 4. The optimum working temperature for the **AGM G2** is from 0°C~40°C. Charging the phone outside this temperature range will damage the battery and shorten battery life.
- * Please do not charge the phone under extremely low or high temperature, Please charge the phone under 5°C~40°C. Otherwise the battery will be damaged or exploded.**
5. Please use the certified charger and cable to ensure maximum performance and safety.
 6. Please note that the battery will still discharge itself even when the phone is not in use and switched off. If you plan to not use the unit for an extended period, you should still charge it a least every two months to prevent complete power loss and to protect your data.

FREQUENTLY USED FUNCTIONS

Lock/Unlock the screen:

Press the POWER key

The phone screen will be locked when the phone is not in use

Unlocking the phone:

Press the POWER key to unlock the screen and slide the screen up to unlock the phone.

Taking a Screenshot:

Press the POWER key and VOLUME DOWN key at the same time

Making a call:

1. Touch the phone icon on home screen
2. Open dial pad and input phone number
3. Touch the call record icon to check call records
4. Touch contact icon to check contact menu

Sending a MSM:

1. Touch the message icon on home screen
2. Create a new message
3. At the top of the screen, enter a phone number or select a contact. Type your message, then send

Send an email:

1. Touch the Email icon on the Home or All Apps screen
2. If you have already signed into an Email account during setup, your email will be synchronized to your device. Otherwise, add an email address now

WIFI Connection:

1. Touch the Settings icon to enter Settings menu
2. Touch the WIFI icon to enable or disable WIFI

Enabling Data:

1. Touch the Settings icon to enter the Settings menu
2. Touch the SIM card icon to enable data connection
3. Disable data connection when not use

Location Services:

1. Touch Settings icon to enter Settings menu.
2. Touch Location icon to turn on/off location services.
3. Turn off Location Services to save power when not in use.

Adding a Language:

1. Touch the Settings icon to enter Settings menu
2. Touch the Language icon and select Language
3. Touch Add icon to choose your language
4. Press and Hold the language you have chosen and move to top

Taking a Photo/Video:

Normal Photo/Video

1. Touch the Camera icon to activate camera menu
2. Touch the shot icon to take a photo.
3. Touch the switch icon to switch rear and front camera.
4. Touch the view icon to check photo or video history.
5. Touch the video icon to shoot a video.

Night Vision Photo:

1. Touch the Camera icon to activate camera menu
2. Touch the Night Vision mode icon to enter Night Vision mode
3. Touch the shot icon to take a Night Vision photo

Macro Photo

1. Touch the Camera icon to activate camera menu
2. Touch the Macro mode icon to enter macro mode
3. Put the phone camera close to object
4. Touch the shot icon to take a macro photo

FUNCTIONS SHORTCUT MENU

1. Pull down from status bar and open notification panel.
2. Press the shortcut icon to activate/ de-activate the functions.

ADDITIONAL FUNCTIONS

Thermal Imaging Camera

Click APP IRCamera to turn on the function

Thermal Imaging Notice:

To ensure the safety of the users and the device, please read the all following instructions carefully before you use the device.

1. **During the use of the thermal camera, do not point directly at extremely high-intensity thermal radiation sources, such as the sun, laser, spot welding machine, etc., it could burn the module and cause permanent damage.**
2. **The ideal working temperature is -10 °C ~ 50°C.**
3. **Please DO NOT crack the lens to any sharp or hard object.**
4. **Please DO NOT use corrosive solution to clean the lens.**
5. **Please be AWARE of static electricity.**
6. **Please DO NOT disassemble the device. If any fault occurs, please contact AGM for professional repair.**

Google apps

Google provides entertainment, social network, and business apps. You may require a Google Account to access some apps. Refer to Accounts for more information.

To view more app information, access each apps in the help menu.

Tips:Some apps may not be available or may be labelled differently depending on the region or service provider.

Chrome

Search for information and browse webpages.

Gmail

Send or receive emails via the Google Gmail service.

Maps

Find your location on the map, search for locations, and view location information for various Places.

YT Music

Discover, listen to, and share music on your device.

Play Movies & TV

Watch videos stored on your device and download various content to watch from the Play Store.

Drive

Store your content on the cloud, access it from anywhere, and share it with others.

Google

Search quickly for items on the Internet or your device.

Play Store

Download third-party apps from the Play Store

Duo

Video and voice calls over the network.

Google, Google Play, Gmail, Chrome and other marks are trademarks of Google LLC.

WARNING



At full volume, extended use of the mobile audio player may damage the user's hearing.

Please install only officially released applications for the **AGM G2**.
AGM is not responsible for any 3rd parties' application data.

COMPLIANCE

This device complies with the essential requirements and other provisions contained in Directive 2014/53/EU.

Basic information of manufacturer

Company: SHENZHEN AIJIEMO SCIENCE AND TECHNOLOGY CO., LTD
Product name: smart phone
Copyright © AGM Mobile Limited
2021. All rights reserved.

THIS DOCUMENT IS FOR INFORMATION PURPOSES ONLY, AND DOES NOT
CONSTITUTE ANY KIND OF WARRANTY.